

Solving Mobile Radar Measurement Challenges

By Dingqing Lu, Keysight Technologies, Inc.

Modern radar systems are exceptionally complex, encompassing intricate constructions with advanced technology from multiple engineering fields. Accurately detecting moving targets in these multifaceted environments is difficult given the detrimental effects of interference on precision measurements. The adoption of a simulation technique provides a design-oriented value proposition of shortening the development period, thereby saving time and money by avoiding unnecessary field tests. This measurement solution promises lower product risks, reduced costs, higher system performance, and customization and ease of use.

The following discussion examines an alternative simulation method that allows for better cross-domain modeling in a single framework to capture the complete effects of modern radar system performance.

The Challenge: Increasing Accuracy and Decreasing Cost

The interference involved in mobile radar measurements poses a large challenge for radar designers and operators alike. Stated simply, any form of interference in the radar system floods the receiver with irrelevant and distracting noise or false information. This overload of unwanted data makes it impossible to analyze and measure the desired data. The system is essentially overrun with irrelevant information, and no essential data may be collected. In order to properly address these issues involved in mobile radar measurement, it is most optimal to create a simulation of the scenario.

Scenario Framework Simulation

The use of a simulation allows for elimination of interference, guaranteeing accurate measurements. The “Scenario Framework Simulation”(SFS) technique can be easily implemented, lessening the difficulties involved in testing. The use of the SFS technique presents a solution to the problems faced during the performance of mobile radar

measurements. Expenditures are decreased, while accuracy and efficiency are successfully boosted. Any scenario may be modeled, measured, and accurately understood, enabling superior performance in the physical application of the scenario.

Advantages of Scenario Framework Simulation

- Ability to model any system
 - Monostatic ground-based systems, more complex multistatic systems, and phased array systems
- Supports motion of radar transmission and receiving platforms and targets
- No field-testing costs, efficiency increased, test times reduced

Design Challenges

Designing advanced radar systems is a challenge when one considers the complexity of the operating environment and the fact that these systems are becoming less reliant on traditional RF design, and pushing more and more functionality in baseband signal processing and DSP. The ability to model the complexity of the operating environment, while accounting for the interaction between baseband DSP, RF, and antenna systems, can be a real challenge with existing system-level engineering methodologies. Further, it is vital that new systems capable of providing operational differentiation and advantages be deployed quickly. Not only does this provide tactical advantages, it also delivers economic advantages to the companies who can deploy systems the quickest with the highest possible performance and capability.

Radar designers demand a platform for testing radar receiver processing algorithms, with the capability to handle complex operational environments. Simulation fulfills these demands and moves testing into the lab. The extensive expenses involved in field-testing place a burden on the tester. The use of a simulation promises not only the most accurate results, but also the least expensive and most expedient path to accurate data.

The Solution: Scenario Framework Simulation

In order to better understand the importance of implementing this simulation technique, a brief explanation of how it functions is beneficial. Given the number of different radars, and the inconsistencies between them, a generalized simulation tool is essential to accurately model all scenarios. A standardized simulation uses the basic assumptions involved when testing radars. That is; no matter what type of radar, the signals are always transmitted from some radar system, and received by themselves or by other radar systems. When using the SFS, this standardized simulation is implemented.

SFS Design

While setting up the simulation framework in the testing device, there are three layers to consider; the trajectory layer, the antenna layer, and the signal layer (Figure 1).

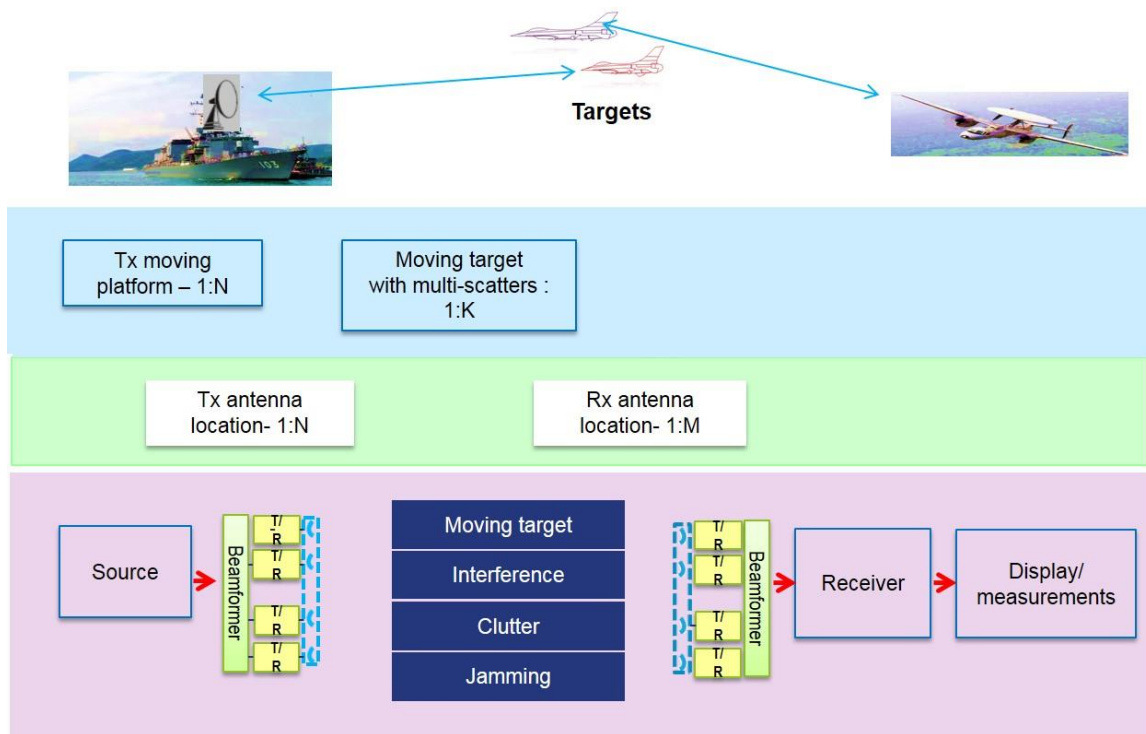

Figure 1. A diagram of the scenario framework simulation using Keysight's SystemVue software. Simulation allows for total replication of any radar scenario, eliminating the need for costly field-testing.

The Three Layers

- **Trajectory Layer:** locates all receivers and transmitters in 3-D position, velocity

and acceleration spaces

- A radar platform model and radar target trajectory model are used to compute trajectories
- **Antenna Layer:** tracks rotational attitude (pitch, yaw, roll) and beamforming directions
 - Azimuth angle and elevation angle of targets in antenna frame computed to calculate final antenna gain
- **Signal Layer:** measures traditional baseband signal processing paths (MATLAB, HDL, RF models)
 - Signals delayed, attenuated, amplified by antenna and Tx/Rx chains

The signals received by radar systems are the signals from transmitters and the echoes from targets or the different scatters of targets. The distance between transmitters and targets, and between targets and the receiver, decides the delay values of each sample of echoes, which finally decide the magnitude attenuation and Doppler. In addition to the above parameters, the position between the transmitter and the target and the direction of the antenna mainlobe relative to the antenna carrier decide the transmitter antenna gain. The same is true for the receiver antenna gain. Given this basic framework, one can now model any number of radar systems.

Measurements

Once the various layers of the simulation are set up, one can begin to make many different types of advanced radar measurements, ranging from basic spectrum or signal-to-noise ratio (SNR) measurements, to detection and False Alarm probability. Figure 2 illustrates several different types of plots that can be generated to help provide a detailed visual of the desired simulation.

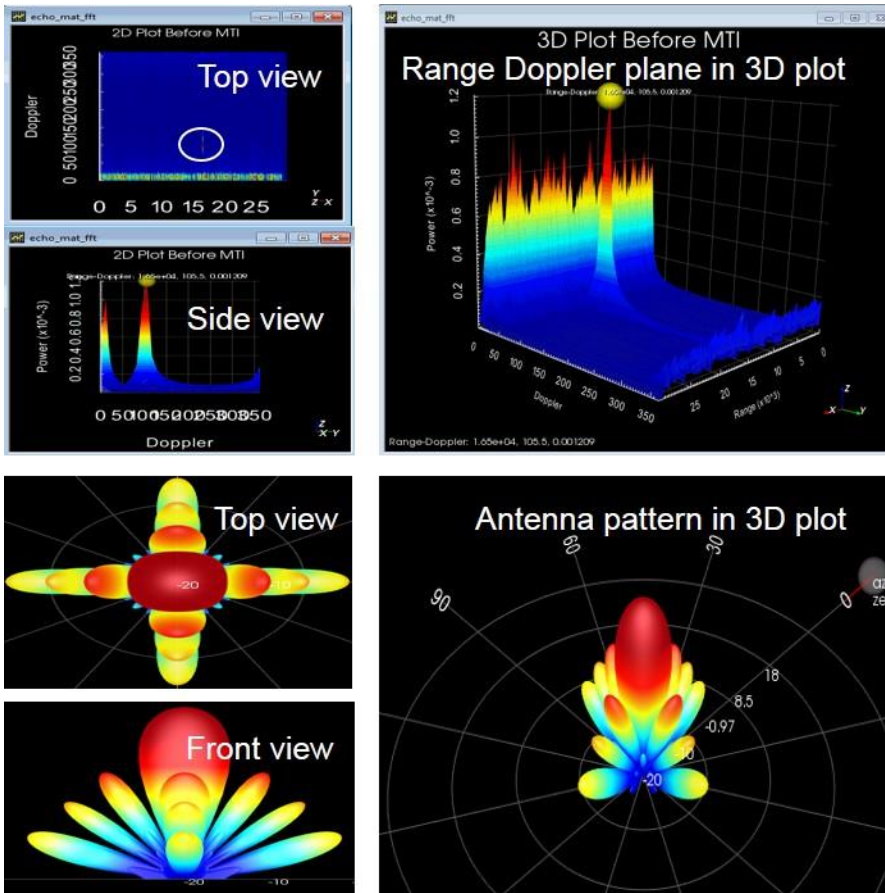

Figure 2. SystemVue simulation allows for many advanced measurements, including detection probability, and false alarm probability. Use of the program allows the user to account for all interference and successfully remove it from data and results.

Now that the basic system set up and functionality of this simulated approach are clear, we address a specific example to demonstrate the capability this scenario has of solving difficulties associated with mobile radar measurements.

Overcoming Interference Issues: A Simulation Model

The advantages of implementing a scenario framework simulation technique are best underscored when applying its capabilities to a specific model. To gain a clearer understanding of the benefits of adopting this method, we dive into a specific example, which highlights the advantageous nature of this simulation model.

Example: Airborne Radar in Lookdown Mode

Consider an airborne radar in lookdown mode under surface clutter, where the operator wishes to simulate a moving platform that is also tracking a moving target. In this scenario, there are several considerations that need to be addressed in order to fully and accurately simulate the setting, including surface clutter, target RCS, and any jamming/deception techniques used by an opposing threat. When performing measurements, there is much interference. One of the main issues faced in moving radar measurements is clutter. Surface clutter essentially refers to any area-based clutter that can exist on both land and sea, and typically becomes an issue in airborne radars in the lookdown mode. In order to adequately account for clutter and all other forms of interference, several measurements must be performed precisely in order to obtain accurate results.

Measurements:

- Waveform and spectrum calculation of Detection Probability
- Creation of 3D plot of Range-Doppler Plane
- Estimation of range and Doppler effects

Simulation Setup

The first step in setting up the simulation is to construct the three layers previously discussed. For the platform setup, assume the airplane is flying with a certain velocity V_T and the initial location in LLA is Longitude R , Latitude R and Altitude R . Using the Radar Platform model, Tx, we can specify Tx and Rx platforms in the **Trajectory Layer** as seen in Figure 3. We can do the same thing for the target model. Target location and speed can be set up using the Radar Target Model. If the user wants volume target, this model also allows them to specify multi-scatters in one target.

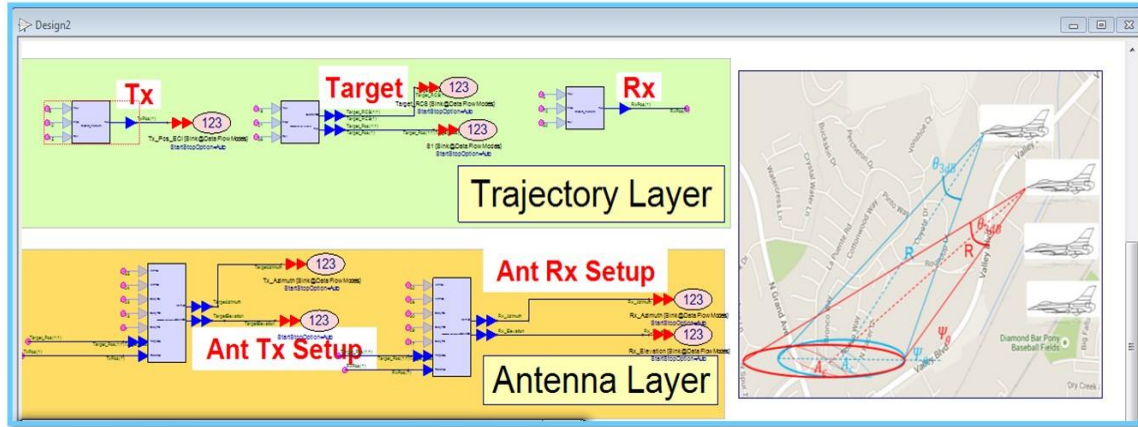

Figure 3. Trajectory and Antenna Layer setup in SystemVue.

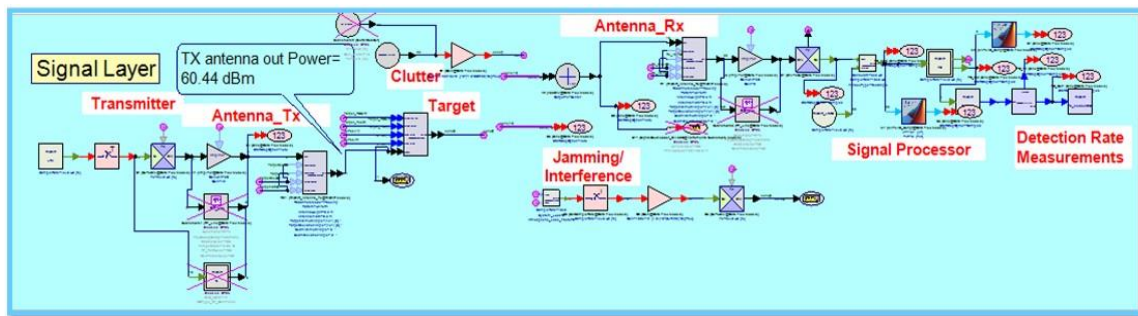

Figure 4. Signal Layer setup in SystemVue.

Once the **Signal Layer** has been set up, as shown in Figure 4, it is time to consider the **Physical Layer** setup. An LFM signal is used by default. Custom waveforms such NLFM or coded signals can also be used very easily. Under the “RF Transmitter” parameter there are several options with which the data can be formed, including Analog/Digital and Cross-domain simulation. Phased array models are ready to be used. Detection Environments such as target RCS, Clutter, Jamming/Deception have been considered. A radar signal processing algorithm such as MTI, MTD are put in the radar receiver.

Results

Once the layers have been set up, many measurements, including those shown in Figure 5, can be set up to characterize the different elements of the scenario. To summarize, the three layers were set up, the physical layer was formed, the detection environment (clutter) was considered, and now appropriate measurements may be performed. All

forms of interference may now be accounted for and accurately modeled in this system framework. This simplistic approach to airborne radar measurements demonstrates not only its power, but also the ease of use. This example may be modeled on any number of different radar scenarios; the universal quality of the scenario framework simulation enables testing of all kinds of radar signals and situations. Once the basic framework has been achieved, any environmental interference may be easily accounted for within the calculations of the software, and thus, accurate results are guaranteed.

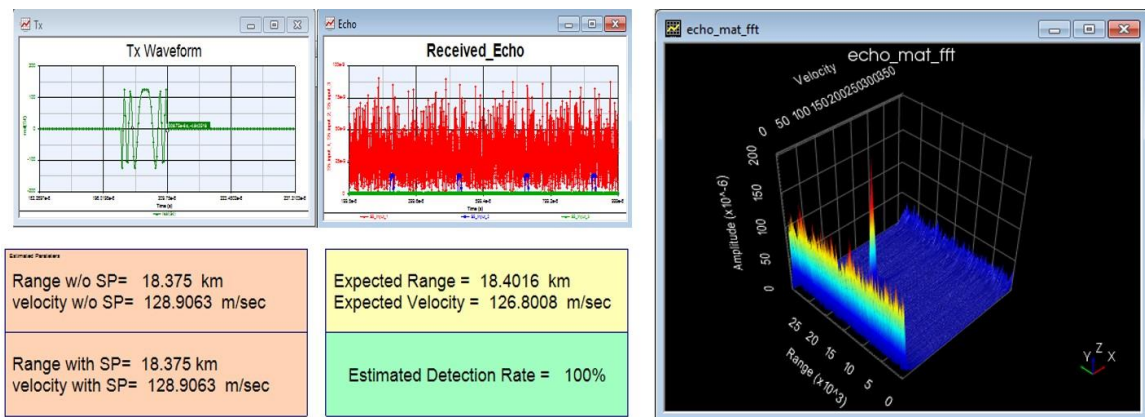

Figure 5. Once the platform is successfully set up, the user can adjust and measure for all forms of interference, thus guaranteeing successful results.

Radar scenario simulations can be challenging to design and test, especially when they are airborne. The new simulation approach successfully addresses these challenges. To save development time and reduce cost, simulation of different radar scenarios is paramount. These scenarios can include radar signal generation and processing, as well as environmental effects and simulated platform and target hardware specific parameters. The capability to simulate the full deployment environment enables exceptional development speed and provides rapid prototyping capabilities for any radar system development. By moving testing into the lab and away from the field, time and money are spared, while measurement accuracy is improved.